

| REV.NO | REVISION RECORD | DATE | CK |
|--------|-----------------|------|----|
| 1      |                 |      |    |

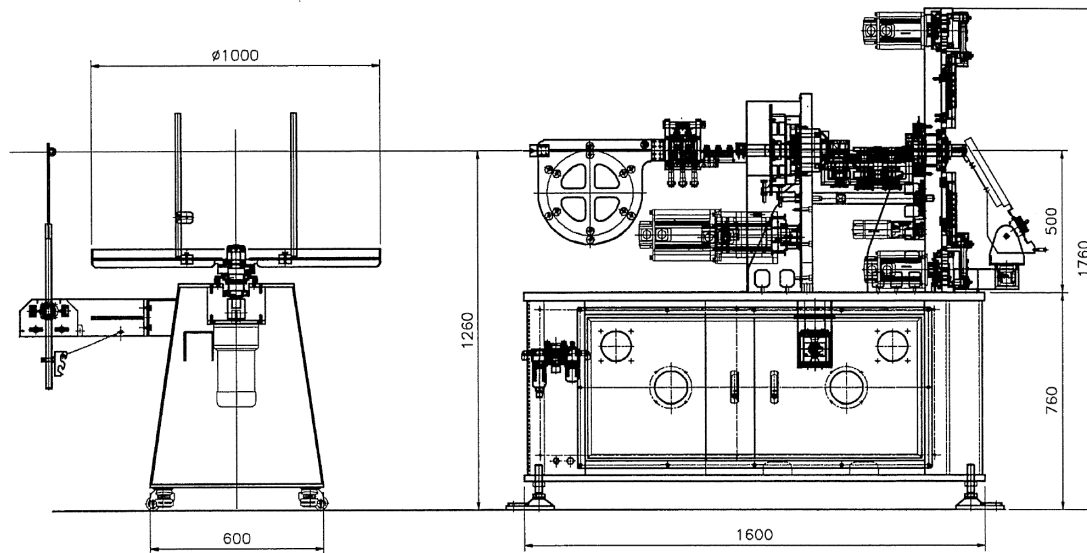
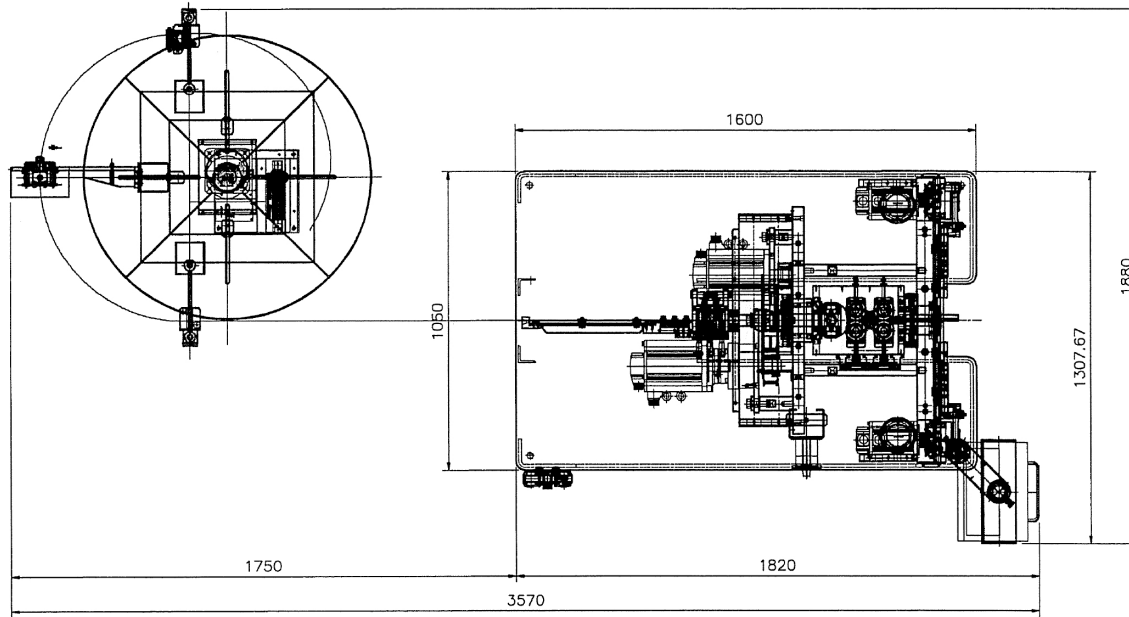

| NO.  | PART NAME | MATERIAL | QUANTITY | WEIGHT | REMARK                |
|--|-----------|----------|----------|--------|-----------------------|
| SPRING FORMING MACHINE-NMCL25<br><br>LAY-OUT |           |          |          |        | DRAW<br>DESIGNED      |
|  |           |          |          |        | CHECKED               |
|  |           |          |          |        | APPROVED              |
|  |           |          |          |        | DATE 2013. 02. 04     |
|  |           |          |          |        | DWG NO. NMCL25-01-A-1 |
|  |           |          |          |        | REF NO.               |